

# Design of Tracked Robot with Remote Control for Surveillance

Widodo Budiharto

School of Computer Science  
Bina Nusantara University  
Jakarta- Indonesia  
Email:wbudiharto@binus.edu

**Abstract**—For specific purpose, tracked robot that can be controlled remotely and able to acquire images from environment is very important, for example in rescuing disaster victims. We propose architecture for Raspberry pi and AVR-based mobile robot that can be controlled by low cost remote controller Integrated Circuits(IC) and able to avoid obstacles using ultrasonic distance sensor. This prototype also can be used for education and research in the university. We evaluate the performance of the robot in terms of the distance and the capability to deliver video streaming from the output raspberry pi and 2.4 GHz Video transmitter.

**Keywords**—mobile robot, remote control, AVR, obstacle avoidance

## I. INTRODUCTION

Robotics has been a staple of advanced manufacturing for over half a century. As robots and their peripheral equipment become more sophisticated, reliable and miniaturized, these systems are increasingly being utilized for military and law enforcement purposes. A remote control robot is defined as any robot that is remotely controlled by a means that does not restrict its motion with an origin external to the device. Mobile robot with controlled remotely have important rules in area of rescue and military.

Surveillance is the monitoring of behavior.. Robot surveillance has a function to monitor the behavior of people, objects or processes within systems for conformity to expected or desired norms in trusted systems for security or social control. The technological evolution of video based surveillance systems started with analogue closed circuit television (CCTV) systems [1].

A rescue robot is a robot that has been designed for the purpose of rescuing people. Common situations that employ rescue robots are mining accidents, urban disasters, hostage situations, and explosions. Military robots are autonomous robots or remote-controlled devices designed for military applications. Such systems are currently being researched by a number of militaries. US Mechatronics has produced a

working automated sentry gun and is currently developing it further for commercial and military use that can be operated remotely, and another very popular is The Multi-Mission Unmanned Ground Vehicle, previously known as the Multifunction Utility/Logistics and Equipment vehicle (MULE) [2][3].

Dealing with varied terrain places extra demands on the mobile robot's propulsion system, among other systems. Power management and new generation drive-train systems utilize advanced materials and highly efficient transmissions to obtain higher speed, accuracy as well as durability to work in a wide range of environments. Enhanced power management comes through more advanced fuel cells and newly designed battery and charging systems.

Configuring a robot to ascend and descend obstacles in unstructured environments with ease is a design challenge and uses more power. The system must be able to overcome both regularly shaped obstacles such as stairs and those of an unspecified shape such as rocks, downed trees and other miscellaneous objects. Engineers must consider the center of gravity, torque requirements to ascend inclines, mass, and payloads when designing mobile robotic systems for military purposes. In military applications, wearable robotics help soldiers carry a heavy pack load. A robot acts like a pack mule, is fully autonomous, and carries a large amount of supplies [4].

There are many microcontrollers in the market consist of various type capability from basic input output to high end microcontroller. These various types of microcontroller are purposes made for general application. In this research, we propose architecture for Raspberry pi and AVR-based mobile robot that can be controlled by low cost remote controller with the capabilities to avoid obstacles. Microcontroller ATmega32 with 16 MHz is used because capable to store 32k program at EEPROM that suitable for intelligent mobile robot. We also propose DC Motor driver and DC Motor with gearbox in order this system able to handle heavy load to accomplish the task.

## II. DESIGN OF TRACKED ROBOT WITH OBSTACLE AVOIDANCES CAPABILITIES

### A. Architecture of mobile robot

The robot used in this research is a mobile robot which is equipped with two actuator wheels and is considered as a system subject to non holonomic constraints. Basically, representing mobile robot with differential drive can be shown at figure 1, it consists of initial frame  $\{X_I, Y_I\}$  and robot frame  $\{X_R, Y_R\}$ . The combination of wheel rolling and sliding constraints describes the kinematic behavior. Usually, robot speed as a function of wheel speed and the position can be determined by equation:

$$\xi_I = [x \ y \ \theta]^T \quad (1)$$

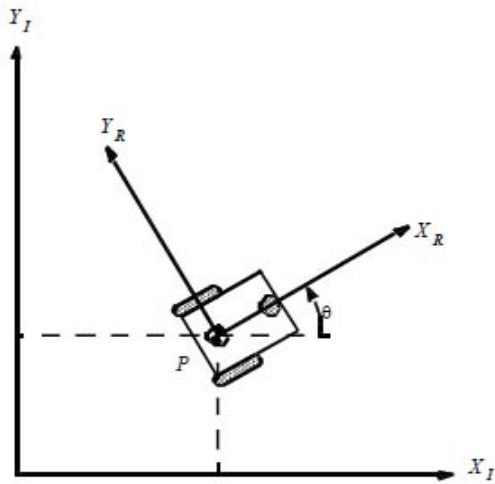

Fig. 1. Representing Mobile Robot

Figure 2 is a proposed block diagram of very low cost tracked robot that consists of RC Receiver, distance sensors, main controller, 5A Driver DC Motors and DC Motors with Wheels. For the driver of DC Motor, we use MOSFET with the low resistance of the drain-source. The Raspberry Pi is a credit-card sized computer that has AV output. It is a capable little computer which can be used in electronics projects, and for many of the things that your desktop PC does, like spreadsheets, word-processing and games. It also plays high-definition video [10].

We use 2.4 GHz Video Transmitter that able to transmit about 100 meters and receive the data using 2.4 GHz Video Receiver. At the same time the transmitter transmitting the video from Raspberry pi, the AVR microcontroller also receive commands for robot from the Remote control receiver.

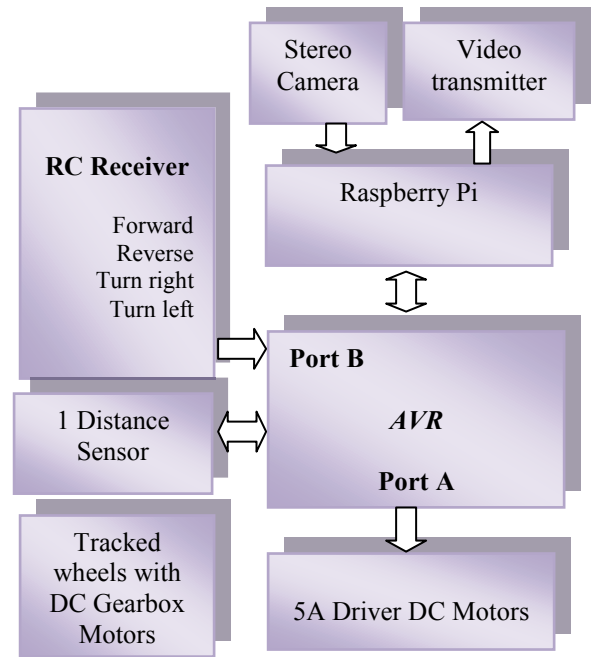

Fig. 2. Architecture of tracked robot with remote control and image processing capability. Video transmitted using 2.4 GHz Transmitter.

For remote control, we use general schematics for transmit and receive command using IC TX-2B/RX-2B, a pair of CMOS LSIs designed for remote controlled car applications. At a receiver, the 4 output will act as input to microcontroller. While user move a robot, at the same time 3 ultrasonic distance sensors will detect the obstacle at the front, left and right side of the robot to avoid collision with the obstacles.

PING)))™ ultrasonic sensor provides an easy method of distance measurement. This sensor is perfect for any number of applications that require you to perform measurements between moving or stationary objects. Interfacing to a microcontroller is a snap. A single I/O pin is used to trigger an ultrasonic burst (well above human hearing) and then "listen" for the echo return pulse. The sensor measures the time required for the echo return, and returns this value to the microcontroller as a variable-width pulse via the same I/O pin.

The TX-2B/RX-2B has five control keys for controlling the motions (i.e. forward, backward, rightward, leftward and the turbo function) of the remote controlled car as shown in figure 3 and 4 below:

RECOMMENDED APPLICATION CIRCUIT

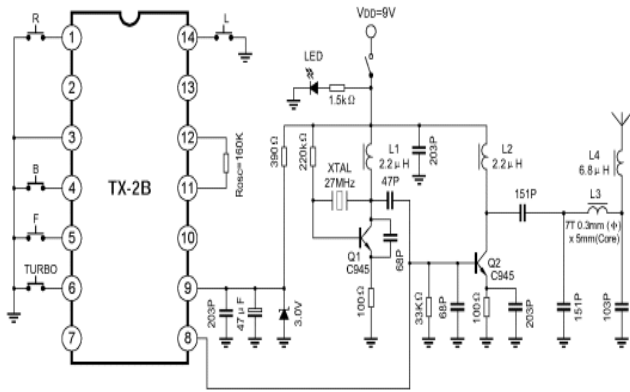

Fig. 3. Schematic of transmitter 27 MHz

The schematic for receiver system that have 4 outputs using Push pull transistors (forward, reverse, turn left and turn right) and the outputs connected to port C of the microcontroller system show in figure 4:

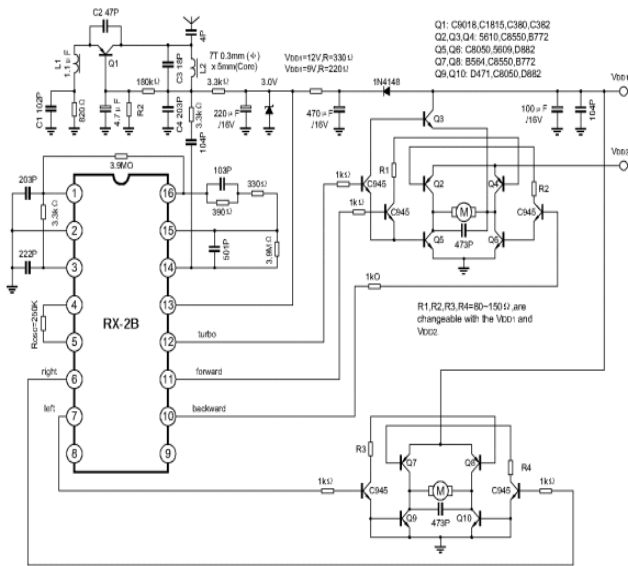

Fig. 4. Schematic of receiver 27 MHz

At previous work [7], we prove that our method using 3 distance sensors enough for detecting obstacle, so we implement that method for this research. Ultrasonic sensors work at a frequency of 40 KHz and have a deviation angle maximum of about 30°, so usually robots need more than one sensor to be able to measure the distance of an obstacle in its vicinity. The main weakness of this type of sensor is the interference between different sensors and the limited ability to identify the obstacle. The advantage of this type of sensor is that it is usually able to detect the obstacle at a distance  $\geq 3$  cm, something a vision sensor is not able to do.

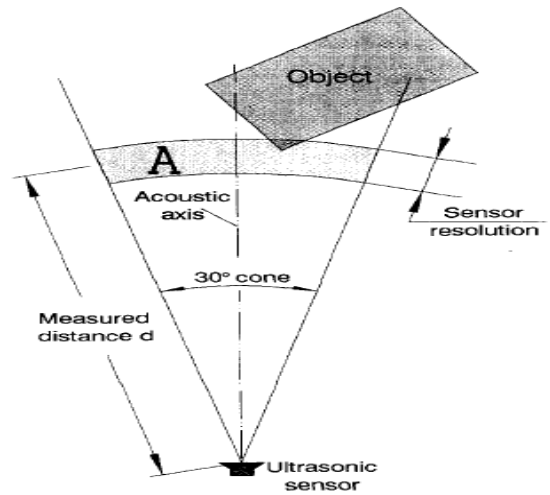

Fig. 5. 2 dimension projection from conical fields of ultrasonic sensor. The distance measurement d indicates the existence of an object in the area [7].

The PING))) sensor detects objects by emitting a short ultrasonic burst and then "listening" for the echo. Under control of a host microcontroller (trigger pulse), the sensor emits a short 40 kHz (ultrasonic) burst. This burst travels through the air, hits an object and then bounces back to the sensor. The PING))) sensor provides an output pulse to the host that will terminate when the echo is detected; hence the width of this pulse corresponds to the distance to the target.



Fig. 6. 1 PING)))™ as distance sensor for obstacles avoidance and Minoru 3D stereo camera for robot[5].

Many techniques have been developed to carry out obstacles avoidance efficiently by using recent sensor data [8]. And robot motion planning is important in this issue [9]. In our method, we make a simple decision to check whether there is obstacle or not by use 2 variables, far and near. Far if there is

no obstacle(>60cm), and near if the distance between robot and obstacle is < 60cm.

### B. Algorithm

I have developed algorithms and programs consisting of 3 main modules, namely the receiver module, the obstacle detection system and the maneuvering method. The algorithm is shown in algorithm 1:

#### Algorithm 1: Remote controlled mobile robot

```

Declare variables
Declare functions
Set all motors off
Initialize the sensors
Far is greater than 60cm
Near is below 60cm
Do
  Call Read_Receiver()
  Call ObstacleDetectionSystem()
  Call ManeuveringMethod()
Loop
Function Read_Receiver
  Accept input from Port C.0,C.1, C.2 and C3
  Return port C status(direction of stick)
End function
Function ObstacleDetectionSystem
  Read front, left and right sensors
  Return distance status
End function
Function ManeuveringMethod
If stick is forward position then and front distance is far
  Call forward
End if
If stick is forward position and front distance is near then
  Call forward
End if
If stick is turn right then
  Call turn_right
Endif
If stick is turn left then
  Call turn_left
Endif
If stick is forward and turn right then
  Call turn_right
Endif
If stick is forward and turn left then
  Call turn_left
Endif
If stick is reverse position then
  Call reverse
End if
End function

```

### III. EXPERIMENTAL RESULT

Our proposed method for remote controlled mobile robot has been successfully implemented and it has shown a good

performance. 1 ultrasonic sensor succeeded to detect and measure the distance of obstacle continuously as shown in table 1:

TABLE I. MEASUREMENT OF DISTANCE FOR CONTROLLING THE ROBOT

No	Evaluation	
	Distance	Status
1	10	Success
2	15	Success
3	20	Success
4	22	Success
5	23	Success
6	25	Failed

Another important result are the robot able to handle up to 10 Kg load because we use high quality body of robot and DC Motor with gearbox with specification 56RPM and torque 588mN.m. The average speed raspberry pi to display a video streaming is 33 fps that sufficient for surveillance.

### IV. CONCLUSION

This paper presents a new method of tracked robot for surveillance with obstacles avoidance capabilities for general purpose robot in indoor environments. Algorithms to receive commands from remote controller and obstacles avoidance to maneuver were implemented in the robot. Experimental results with various distance show that the best distance for transmitting the commands not more than 20 meters. The image processing from video and obstacle avoidance proposed has shown a good performance. The sensor system is very cheap because it only uses 1 distance sensor. The average speed raspberry pi to display a video streaming is 33 fps that sufficient for surveillance. For the future, we will model a navigation system based on fuzzy type-2.

### ACKNOWLEDGMENT

This research supported by BINUS University, Jakarta-Indonesia.

### REFERENCES

- [1] S. Pratheepa and P. Srinivasan, Surveillance Robot for Tracking multiple targets, International Journal fo Scientific and Engineering Research, vol.2, issue 3, pp. 1-4,2011.
- [2] T. Hellström, "On the moral responsibility of military robots". Ethics and Information Technology, **15** (2): 99–107, 2013.
- [3] K. Brannen, "Army kills off MULE unmanned vehicle", Military Times, 15 August 2011.
- [4] Robotics.org, accessed on May 10<sup>th</sup> 2014.
- [5] Parallax.com
- [6] C. Gerald, "Mobile Robot:Navigation, Control and remote Sensing", Wiley Publisher, 2011

- [7] W. Budiharto, et al, "A New Obstacle Avoidance Method for Service Robots in Indoor Environments", *Journal of Engineering and Technological Science*, Vol. 44, No. 2, pp.148-167, 2012. DOI Number : 10.5614/itbj.eng.sci.2012.44.2.4
- [8] O. Khatib, , Real-time Obstacle Avoidance for Manipulator and Mobile Robots, *International Journal of Robotics Research* 5(1), pp.90-98, 1986.
- [9] E. Masehian and Y. Katebi, Robot Motion Planning in Dynamic Environments with Moving Obstacles and Target, *Int. Journal of Mechanical Systems Science and Engineering*, 1(1), pp. 20-25, 2007.
- [10] Raspberry pi.org