

Intelligent Service Robot with Voice Recognition and Telepresence Capabilities

Widodo Budiharto and Derwin Suhartono
School of Computer Science, Bina Nusantara University
Jakarta-Indonesia
Email: wbudiharto@binus.edu

Abstract—The objective of this paper is to propose an intelligent service robot in indoor environment with voice recognition and telepresence capabilities. We have assumed that this model of service robot is used to deliver a drinking cup to the recognized customer from the starting point to the destination. We have developed and introduced 3 main modules to avoid obstacle, to recognize commands and telepresence capabilities based on Google App Engine. The detection of obstacles, which is based on the information from the 3 ultrasonic sensors, uses an Interval type-2 Fuzzy Logic for adopting uncertainty. The main contribution of this research is to provide a complete mechanism of communication model between main controllers to other modules in service robot. We present the results of the experiment of the service robot called BeeBot III which implements our proposed method and we also evaluate its performance.

Keywords—service robot; interval type-2; telepresence

I. INTRODUCTION

Intelligent Service robot is an emerging technology that already used today and will be popular for the future. The International Federation of Robotics (IFR) has proposed a definition, "A service robot is a robot which operates semi- or fully autonomously to perform services useful to the well-being of humans and equipment, excluding manufacturing operations. Some service robots consist of a mobile platform on which one or several arms are attached and controlled in the same mode as the arms of industrial robot. A typical application is a service robot that should recognize customers and obstacles indoors or outdoors and accomplish a specific task given by a user. Recognize customer and orders for service robot is a challenging task. A service robot should maneuver to avoid static and moving obstacles and also reach the goal in an optimal manner. This will lead to demand for robust algorithm for face recognition, voice recognition and path planning and autonomy of a service robot [1][2][3][4].

Based on literatures obtained by the authors, many research in development of service robot are conducted such as [1][2][5], whereas task of the service robot is the deliver an order to customer. A Service robot requires deliberation in the form of autonomous planning and communication with humans. At the same time a service robot must be able to react instantly to unexpected situations. In the deliberate layer the architecture needs to understand commands given by a human operator. In the reactive layer of a behavior-based architecture,

behaviors act as tight couplings between sensors and actuators [5].

In office or factory, sometimes manager/supervisor wants to discuss/supervise staffs remotely. So, based on that situation, service robot with feature of telepresence robot can be used on that scenario. However, so far there is no model for service robot with voice recognition and telepresence capability using interval type-2 FLC and web based application framework for video conferencing. The development of an obstacle avoidance system for service robot to accurately detect moving obstacles in indoors is highly complex. Using sensory information to locate the robot in its environment is the most fundamental problem for providing a service robot with autonomous capabilities.

State of the art of this research is to propose the intelligent service robot with voice recognition and telepresence capabilities [6][7]. Type-2 Fuzzy Logic Controller is used for obstacles avoidance and web user interface for video conference. This robot can be used in restaurant with the video conferencing features using WebRTC for controlling the robots on the web and fast movement using omniwheel mechanism. Fig. 1 is or intelligent service robot with single camera, manipulator and Tigel EasyVR Shield [8].



Fig. 1. Intelligent service robot Beebot III

II. PROPOSED MODEL OF SERVICE ROBOT

A. Architecture of the robot

The vision-based service robot is based on the Arduino processor with 3 omni-directional wheels. Omni-directional wheels are unique as they are able to roll freely in two directions. It can either roll like a normal wheel or roll laterally using the wheels along its circumference. Omni-direction wheels allow a robot to convert from a non-holonomic to a holonomic robot. A non-holonomic robot that uses normal wheels has only 2 out of 3 controllable degrees-of-freedom which are moving forward/backwards and rotation. If v is velocity of the wheels, r is omni wheel radius(cm) and ω angular velocity of the wheel (rad/sec), then the velocities are:

$$\begin{bmatrix} v_x \\ v_y \\ v \end{bmatrix} = \begin{bmatrix} -\frac{1}{2} & \frac{1}{2} & 1 \\ \frac{\sqrt{3}}{2} & -\frac{\sqrt{3}}{2} & 0 \\ \frac{1}{L} & \frac{1}{L} & \frac{1}{L} \end{bmatrix} \begin{bmatrix} V_1 \\ V_2 \\ V_3 \end{bmatrix} \quad (1)$$

At our robot, a pole is fitted on the base plate and serves as the elevated attachment point for the laptop, speakers, 1 camera for pointing forward for conversations, single camera from tablet Acer Iconia is used for customer recognition using OpenCV. The robot has an overall height of 85 cm, allowing for natural conversation while standing or being seated. Additionally, obstacle avoidance is implemented using 3 ultrasonic sensors, which provides assistance during manual operation or full autonomous navigation if desired. Interconnecting main controller to service robot as telepresence with manipulator through networks shown in Fig. 2 that can be accessed through LAN using additional PC and browser. To increase mobility of the robot, Ethernet WiFi will be employed and HTTP over TCP is the connection protocol for the robot. The video and audio information will be sent through HTTP based delivery system.

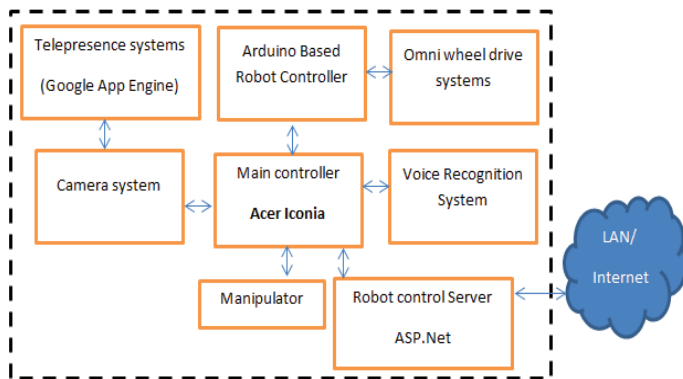

Fig. 2. Proposed communication model of vision-based service robot with 2(two) features: voice recognition and telepresence capabilities

B. Obstacle Avoidance Method

Navigation is an important features for vision-based service robot [9]. Using 3 ultrasonic sensors, theoretically enough to obtain distance information from front, left and right side of robot. So, we propose a model for obstacles avoidance for a service robot as shown in flowchart from Fig. 2. This method is a combination of static and moving obstacle detection using

vision and ultrasonic sensors. Information about static obstacle obtained when robot start to running.

Obstacle avoidance method such as Potential Field Method (PFM) and Virtual Force Histogram (VFH) for obstacle avoidance has gained increased popularity in the field of mobile robots. PFM method based on attractive and repulsive potential fields that guided the robot to reaches the goal or to avoid the obstacle. PFM have inherent limitations such as no passage between closely spaced obstacles, oscillations in the presence of obstacles and in narrow passages and no movement from robot because attractive and repulsive force can balance. VFH is fast obstacle avoidance method based on a polar histogram of obstacles that defines directions for safe travel. VFH also have shortcoming that the result is sensitive to threshold and expensive hardware because using histogram grid world model that is updated by rapidly firing 24 sensors around the robot during motion[10][11].

Type-2 fuzzy logic systems (T2-FLS) make possible to model and handle uncertainties. These are rule based systems in which linguistic variables are described by means of Type-2 fuzzy sets (T2-FSS) that include a footprint of uncertainty (FOU). It provides a measure of dispersion to capture more about uncertainties. While T2-FSS have non-crisp MFs, T1-FSS have crisp membership grades (MGs). Figure 3 show our model of interval Type-2 Fuzzy Logic to avoid obstacle, where distance between robot and obstacles measured using 3 ultrasonic distance sensors [12][13][14][15]. An Interval Type-2 Fuzzy Set is one in which the membership grade of every domain point is a crisp set whose domain is some interval contained in [0, 1].

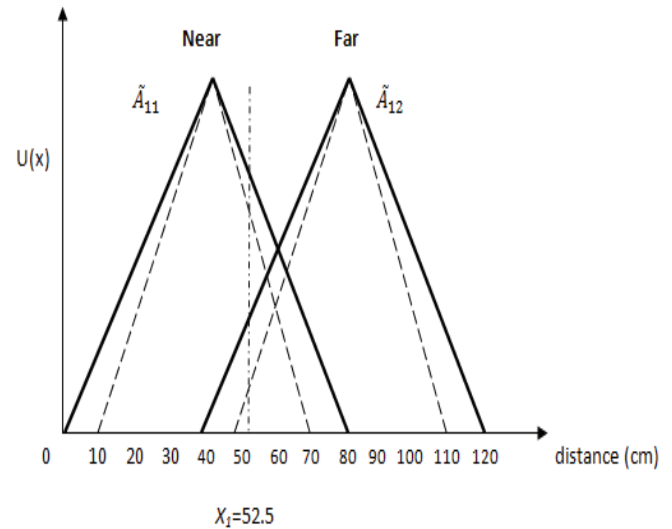

Fig. 3. Interval Type 2 fuzzy logic for measuring distance to navigate the robot[15]

C. Voice Recognition System

The system based on Tegal Voice recognition and Arduino. This module have the ability for users to create up to 28 of their own custom Speaker Independent (SI) Command Vocabularies and Some words used as a main database for conversation as shown below:

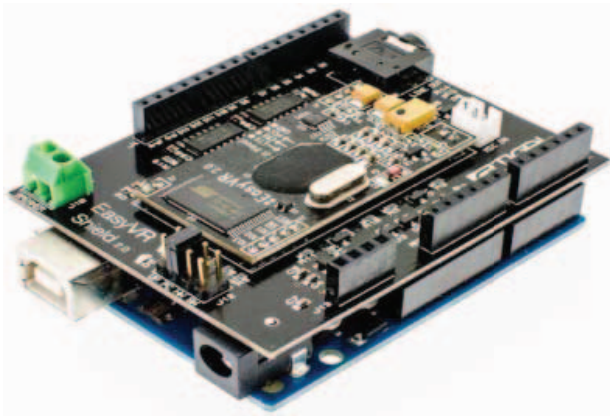

Fig. 4. Voice recognition system using Tigel Easy-VR Shield and Arduino

We use Easy-VR Shield with Arduino. With this shield, you can talk with your Arduino and speak commands to your robot.

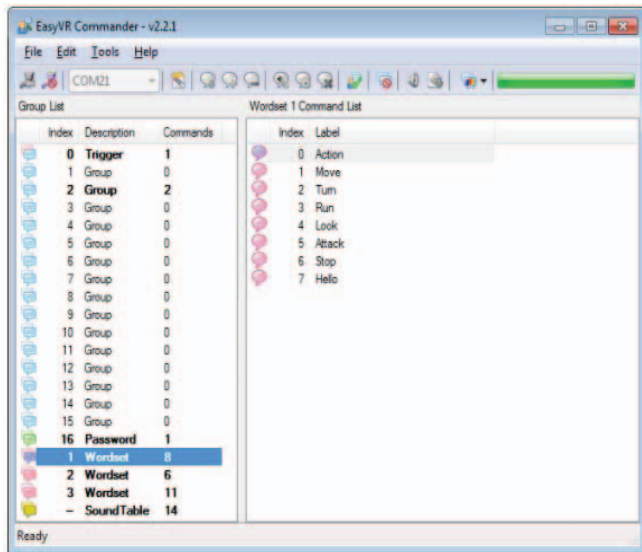

Fig. 5. Using Easy-VR Commander

D. Proposed Algorithm

There are 2 modes, general service robot for delivering a cup/bottle to customer or telepresence robot for communication remotely. The general algorithm for the robot is shown below:

Algorithm 1: intelligent service robot with voice recognition and telepresence capabilities

```
//input mode: general service robot or telepresence
If input =general mode then
Wait for voice commands from user
End if
if input= telepresence mode then
// check if a cup is loaded or not
Checking a cup
Accept command from user
Capture face's images
Face detection and recognition using PCA
if cup loaded and face recognized
```

```
// Visual tracking using camera
While (customer !=center screen)
begin
Heading robot to customer's position
end
if (position of customer at center screen)
begin
Go to customer
call movingObstaclesIdentification
if moving obstacle==true and min_distance=true and
goal=false
maneuvering the robot
end if
Giving a cup
Go to home
end
end if
end
// Function to detect and track a moving obstacle
function movingObstacleIdentification
// Using Haar cascade classifier
moving obstacle detection
if (moving_obstacle==true) then
//estimate distance between robot and moving obstacle
distance estimation // Using Kalman filtering
// estimate velocity and direction of moving obstacle
Calculate  $v_o$ , direction
Endif
Return  $v_o$ , direction
end function
```

III. EXPERIMENTAL RESULTS

Experiments of vision-based robot have been tested for navigating the robot to customer in our office. Customer recognition based on eigenspaces with 3 images per person used and databases for the images have been developed[16]. Based on the experiment, the system run very well with the capability to avoid obstacles and delivering a bottle to the customer. For example, in the general service robot mode show in figure 6:



Fig. 6. General mode of service robot for delivering cup to customers

The web application based on Google app engine for video conferencing is very fast and we satisfied. In the telepresence mode, the user able to control the robot under web as shown below:



Fig. 7. Proposed communication model of intelligence service robot with 2(two) features: voice recognition and telepresence capabilities

TABLE I. COMPARISON OF OUR METHOD

| No | Variables | others | Our method |
|----|---|--------|------------|
| 1 | Complete communication model from main controller to voice recognition system, manipulator, obstacles avoidance and telepresence system | No | yes |
| 2 | Low cost sensors and hardware | No | yes |
| 3 | Remember order from customer | Yes | yes |

IV. CONCLUSION

Intelligent service robot with voice recognition and video conferencing system has successfully been developed in this research. The image is processed through image processing as depicted in Fig. 5 and 6 which is furthermore sent through Internet network using HTTP TCP protocol to the master computer. The sound is sent through Internet by using same protocol with the image. The server receives the image and sound from the robot and then an operator can hear and watch the image. The distance between robot and person is determined by distance sensor located in the base of the robot. Table 1 show the effectiveness and comparison between our method and others. For future work, we will improve the ability of voice recognition system for our humanoid robot as an education and entertainment robot.

ACKNOWLEDGMENT

The authors wish to thank to Indonesian government and RISTEK SINAS grant 2015 who give grant for this research.

REFERENCES

- [1] L. Acosta, E.J. González, J.N. Rodríguez, A.F. Hamilton, J.A. Méndez, S. Hernández, S.M. Sigut and Marichal G.N, Design and Implementation of a Service Robot for A Restaurant, International Journal of robotics and automation, vol. 21 no.4 , pp. 273-281, 2006.
- [2] Y. Qing-wiau, Y.Can, F. Zhuang and Yan-Zheng Z., Research of the Localization of Restaurant Service Robot, International Journal of Advanced Robotic Systems, vol. 7 no. 3, pp. 227-238, 2010.
- [3] J. Borenstein and Y. Koren, The Vector Field Histogram- Fast Obstacle Avoidance for Mobile Robots, in proc. IEEE Trans. On Robotics and Automation, 7(3), pp.278-288, 1991.
- [4] W. Budiharto, A. Santoso, D. Purwanto and A. Jazidie, A New Method for Obstacles Avoidance of Service Robot in Indoor Environment, Journal of Engineering and Technological Sciences, Vol 44B no. 2, pp. 148-167, 2012.
- [5] L. Mattias, O. Anders and I. Henrik, BERRA: A Research Architecture for Service Robots, Proceedings of the 2000 IEEE International Conference on Robotics and Automation, San Fransisco, pp. 3278-3283, April ,2000.
- [6] D.A. Lazewatsky and W.D. Smart, An inexpensive robot platform for teleoperation and experimentation, Proceedings of the IEEE International Conference on Robotics and Automation (ICRA), May 9-13, IEEE Xplore Press, Shanghai, pp: 1211-1216, 2011.
- [7] L. Takayama, E. Marder-Eppstein, H. Harris and J.M. Beer. Assisted driving of a mobile remote presence system: System design and controlled user evaluation, Proceedings of the IEEE International Conference on Robotics and Automation, May. 9-13, IEEE Xplore Press, Shanghai, pp: 1883-1889, 2011.
- [8] <https://www.tigal.com/product/2333>.
- [9] W. Budiharto, D. Purwanto and A. Jazidie, A navigation system for service robot using stereo vision and kalman filtering, Proceedings of the 11th IEEE International Conference on Control, Automation and Systems, Oct. 26-29, IEEE Xplore Press, Gyeonggi-do, pp: 1771-1776, 2011.
- [10] Khatib O., Real-time Obstacle Avoidance for Manipulator and Mobile Robots, International Journal of Robotics Research 5(1), pp.90-98, 1986.
- [11] Borenstein J. and Koren Y., Potential Field Methods and Their Inherent Limitations for Mobile Robot Navigation, in proc. IEEE Conf. on Robotics and Automation, California, pp.1398-1404, 1991.
- [12] J. Mendel, Advances In Type-2 Fuzzy Sets and Systems, Information Sciences , pp. 84-110, 2007.
- [13] H. Hagra, A Type-2 Fuzzy Logic Controller for Autonomous Mobile Robots, Proceedings of the 2004 IEEE International Conference on Fuzzy Systems, FUZZ-IEEE 2004, Budapest, Hungary, 2004
- [14] H. Hagra, Type-2 FLC's: a New Generation of Fuzzy Controllers, IEEE Computational Intelligence Magazine, pp. 30-43, 2007.
- [15] W. Budiharto, B. Kanigoro, M. Ohyver, M. Shodiq, C. Nugraheni, R. Lim and H. Wicaksono, Obstacles Avoidance for Intelligent Telepresence Robot using Interval Type-2 FLC, ICIC Express Letters, vol 8(3), 2014.
- [16] W. Budiharto, D. Purwanto, and A. Jazidie, A Robust Obstacle Avoidance for Service Robot using Bayesian Approach, International Journal of Advanced Robotic Systems. Intech Publisher – Austria, Vol 8(1) pp.52-60, 2011.